

Modular Cooking - Meritus

Electric - Griddle Pan

NEGP 6-75 (ME)



Due to continuous technical development, the image shown may not represent the latest design of the unit.

DESCRIPTION

Modular electric griddle pan powered with 9.6 kW Steady State Surface (SSS) heaters. Equipped with open cabinet.

Usable for contact grilling, starch cooking, shallow braising and frying.

Made of AISI 304 with 1.5 mm top thickness, griddle is made of 20 mm thick AISI 420, knife steel, that prevent rust and deliver good thermal conductivity. Designed with circular drain with nylon plug included for shallow frying. Powered with SSS (Steady-State Surface) that deliver superior temperature distribution and durability.

OTHER AVAILABLE MODELS

- NEGP 4-75 (ME)
- NEGP 8-75 (ME)

MAIN FEATURES

- Powered with 9.6 kW SSS heaters.
- Smooth griddle surface with 504 x 545 mm cooking area. 100 mm deep from the top surface.
- Fully welded griddle constructed of AISI 420 with thickness of 20 mm, preventing rust.
- Circular drain with nylon plug and oil collection drawer included.
- Temperature control from 50 degree Celcius to 300 degree Celcius.
- Thermal-cut off when overheated.

CONSTRUCTION

- External construction entirely with AISI 304.
- Top panel with 1.5 mm thickness. Orbital surface finishing: resistant toward scratches.
- Front panel is constructed of 0.8 mm AISI 304 with satin surface finish.
- Side panel is constructed of 0.8 mm AISI 304 with satin surface finish.
- Adjustable +/- 25 mm AISI leg.
- Nayati connection system between Meritus products on the front panels, cabinets, and splashbacks.
- Cabinet executed with H2 radius.
- Deep drawn front panel to minimize liquid penetration to the internal part.
- Gasket protection behind the knobs to prevent water to seeping in, prolonging main heating regulation parts.
- IPX5 water protection level.

INCLUDED ACCESSORIES

- 1/1 GN food pan for grease waste.
- Nylon plug

OPTIONAL ACCESSORIES

- Power cable, H07RN-F (5 x 6 mm) p/mtr.
- Joint clip ME.
- Swing door 6-75 ME.

PT. NAYATI INDONESIA

www.nayati.com

Nayati reserves the right to make product alterations and or price adjustments at any time and can not be held responsible for any printing errors or omissions.

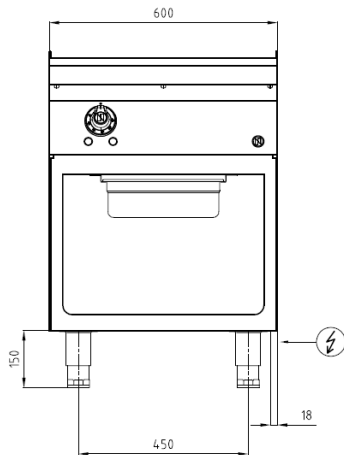
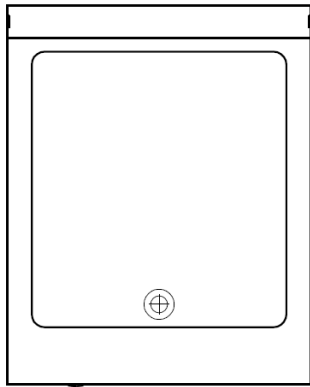
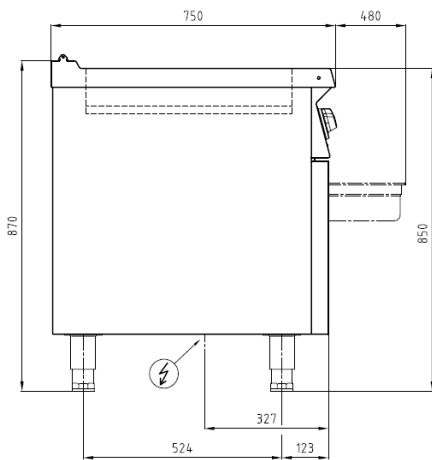
FRONT**TOP****SIDE**

*Overall dimension in mm

TECHNICAL DATA**External Dimensions**

Width	: 600 mm
Depth	: 750 mm
Height	: 850/870 mm

Cooking Surface

Cooking zones	: 28 liters, 504 x 545 mm
Heating zones	: 1
Control type	: Modulating temperature control

Electrical Supply Data

Total connected load	: 9.6 kW
Voltage	: 400V, 3NPE AC /50-60Hz
Recommended fuse	: 6 A (slow)

Connections

Water	: N/A
Drain	: N/A

Heat & Steam Emissions

Direct heat emission	: 3.16 kW
Latent heat emission	: 3.84 kW
Steam emission	: 5.63 kg/h

PACKAGING DATA

Width	: 630 mm
Depth	: 780 mm
Height	: 990 mm
Volume	: 0.49 m ³

WEIGHT

Net Weight	: 90 kg
Gross Weight	: 106 kg