

Modular Cooking - Meritus

Gas - Hot Top

NGHT 12-75 4OB (ME)



Due to continuous technical development, the image shown may not represent the latest design of the unit.

DESCRIPTION

Modular gas hot top with 750 mm depth, powered with 5.7 kW chrome-plated burner. Open burner with two sets of 3.5 kW and 7.5 kW cast iron burner. Static gas oven with 6.5 kW tubular burner. Static gas oven with 6.5 kW tubular burner.

Usable for boiling, steaming, frying, braising, simmering and steam frying. Oven module usable for roasting and baking.

Made of AISI 304 with 1.5 mm top thickness, griddle is made of Molybdenum steel (16Mo5) with 18 mm thickness, powered with circular cast iron burner that heats up the hot top in concentric distribution. Central temperature can reach up to 550 degree Celcius.

OTHER AVAILABLE MODELS

- NGHT 4-75 (ME)
- NGHT 8-75 (ME)
- NGHT 8-75 OC (ME)
- NGHT 12-75 (ME)
- NGHT 12-75 OC (ME)

MAIN FEATURES

- Powered with 5.7 kW chrome-plated steel circular burner.
- Hot top griddle is made of 18 mm thick Molybdenum steel for high thermal performance.
- Concentric heat distribution. Center temperature can reach up to 550 degree Celcius. Griddle center can be removed for service, usable for wok cooking.
- Piezzo ignition system with rubber cover.
- Equipped with flame failure device.

CONSTRUCTION

- External construction entirely with AISI 304.
- Top panel with 1.5 mm thickness. Orbital surface finishing: resistant toward scratches.
- Front panel is constructed of 0.8 mm AISI 304 with satin surface finish.
- Side panel is constructed of 0.8 mm AISI 304 with satin surface finish.
- Adjustable +/- 25 mm AISI leg.
- Nayati connection system between Meritus products on the front panels, cabinets, and splashbacks.
- Cabinet executed with H2 radius.
- Deep drawn front panel to minimize liquid penetration to the internal part.
- Gasket protection behind the knobs to prevent water to seeping in, prolonging main heating regulation parts.

INCLUDED ACCESSORIES

- G20 Conversion Kit
- SS Hook to remove griddle inner plate.
- 2/1 GN oven wire tray (1 pcs.).

OPTIONAL ACCESSORIES

- Joint clip ME.

FRONT

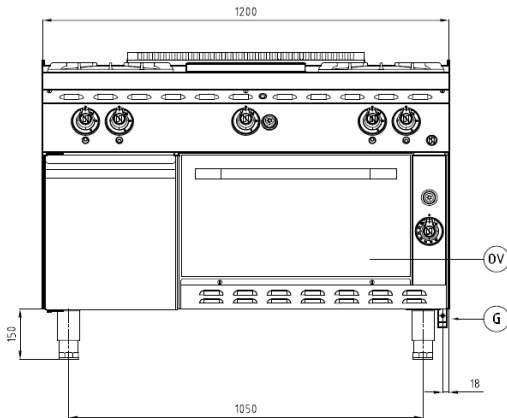

TOP

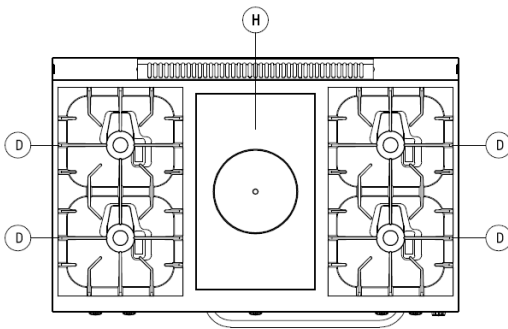

SIDE

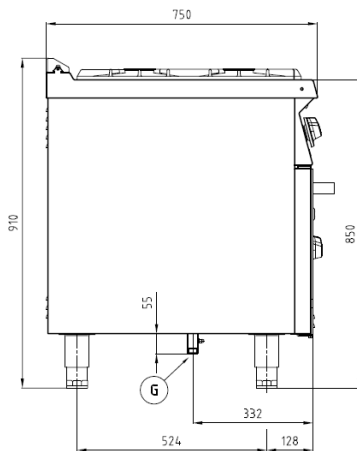

*Overall dimension in mm

TECHNICAL DATA

External Dimensions

Width : 1200 mm
 Depth : 750 mm
 Height : 850/900 mm

Cooking Surface

Cooking zones : Hot Top : 350 x 565 mm, Oven :
 540 x 666 mm, Open Burner : 2 x
 370 x 620 mm

Gas Power Rating

Heat input total : LPG/Natural Gas 34.2 kW
 No. of burners : 5
 Control type : High - low power control
 Gas type options : LPG G30, G31
 Natural Gas G20, G25

Connections

Gas : DN 20 (3/4")
 Water : N/A
 Drain : N/A

Heat & Steam Emissions

Direct heat emission : 9.41 kW
 Latent heat emission : 4.18 kW
 Steam emission : 6.14 kg/h

PACKAGING DATA

Width : 1230 mm
 Depth : 780 mm
 Height : 1020 mm
 Volume : 0.98 m³

WEIGHT

Net Weight : 185 kg
 Gross Weight : 215 kg